

Max. 150°C

**Max. Temperature
Resistance of Components**



**High Temperature Heat Pump
Components**

PREFACE

In the context of the global energy transition, all sectors of the industry are actively promoting the development of "carbon neutral" technology. China's total industrial energy consumption accounts for about 70% of the country's total energy consumption, it is a long-term and arduous task to achieve carbon emission reduction in the industrial field.

Industrial production has a huge demand for high temperature hot water and has traditionally relied on fossil fuel technology. However, as technology advances, we are pleased to see that high temperature heat pump solutions are available for temperatures of 150 °C and below, and their application background is promising.

The high temperature heat pump technology is used to convert the medium and low temperature heat generated in the industrial production process into high temperature hot water or steam for industrial processing or heating. The promotion of this technology not only optimizes the energy structure, but also opens up a new way for enterprises to save energy and reduce emissions. At the same time, the solutions for high temperature heat pumps are also very diverse, such as air source circulation heat recovery, sensible heat exchanger heat recovery, injector switching analog bipolar heat recovery and overlapping bipolar compression, etc. , each has its own advantages and application scenarios.

Of course, it is undeniable that the high temperature heat pump is still in the early stage of development, and currently faces a series of challenges, in addition to system optimization and energy efficiency improvement, the lack of high-performance components also hinders its development. From the point of view of parts, the high temperature compressor bear the brunt, but the high temperature valve is also a major bottleneck, because most of the high temperature heat pump is a non-standard system, the valve on the market has a wide range of requirements. When different refrigerant is used, the exhaust temperature and condensing temperature are different, and a reasonable choice should be made according to the actual situation.

In this field, Sanhua Group actively responds to market demand, fully considers performance, efficiency and economy, and provides a series of high-temperature valve products.

At the same time, Sanhua will continue to be committed to the field of high temperature heat pump, constantly seek the highest temperature resistance breakthrough, and continue to develop new high temperature components, promote the healthy and rapid development of the industry, and contribute to the energy conservation and emission reduction of enterprises and green manufacturing.

CONTENTS

Sanhua@Lists of High Temperature Heat Pump Core Components	02
Electronic Expansion Valve DPF-TS/S Series	03
Electronic Expansion Valve VPF Series	06
Magnetic Check Valve CCV Series	09
Ball Valve SBV Series	11
Ball Valve RBV-R Series	13
Solenoid Valve HDF/MDF Series	15
4 way Reversing Valve SHF-R Series	17
Electric Ball Valve EBV Series for Refrigerant	20
Three Way Electric Ball Valve EBV Series for Refrigerant	23
Brazed Plate Heat Hxchanger BPHE Series	26
Pressure Transducer YCQB series	28
Liquid Line Filter Drier DTGB series	30
Ejector PSQ Series	33
Pressure Switch PSV15 Series	34

Sanhua@Lists of High Temperature Heat Pump Core Components

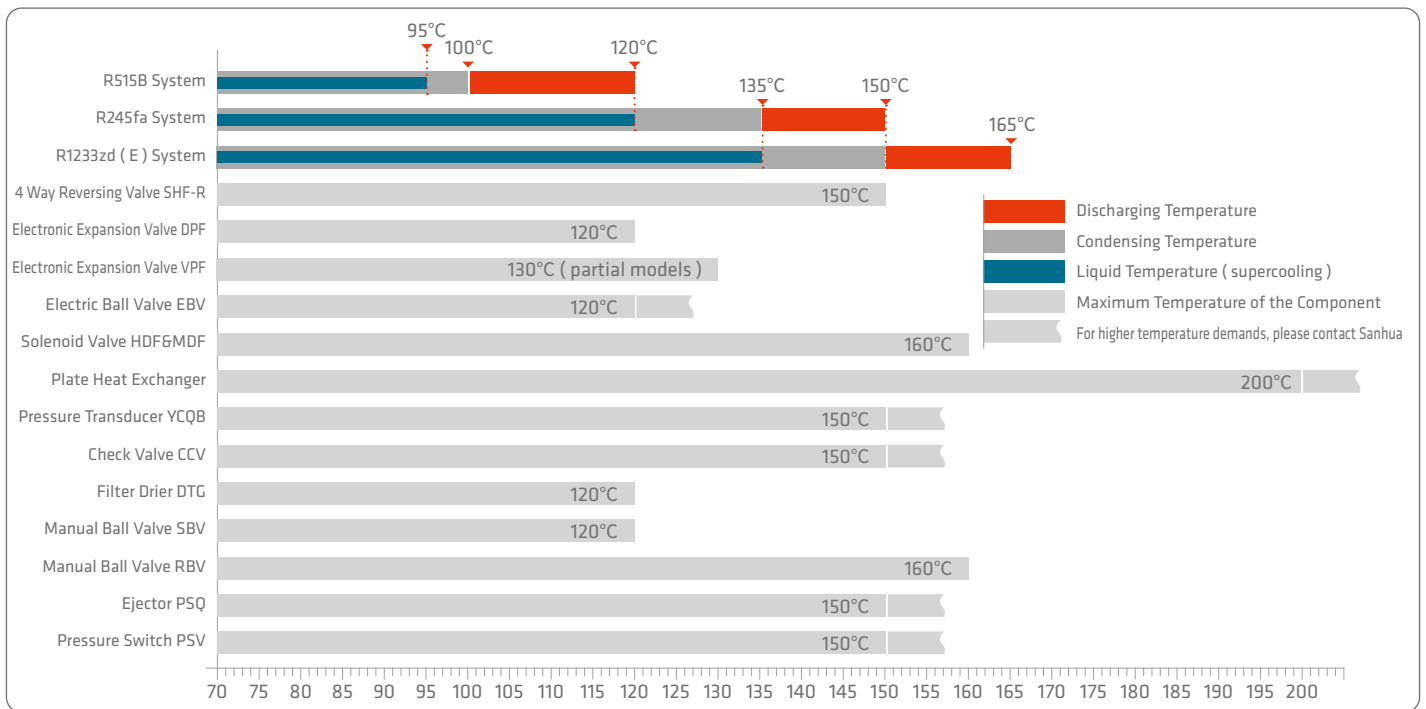

Product	Picture	Series	Max. Medium Temperature	Compatible Refrigerants (Partial)	Recommended Refrigerants (temperature resistance)	System Position	Function	Applicable Range	Key parameters
4 Way Reversing Valve		SHF-R (35-140)	150°C	R515B, R245fa, R1233zd (E), R134a, R123, R32	R515B, R245fa	exhausting side	defrosting	20-80KW@ R515B	Slide and piston all adopt high temperature resistant design MWP: 4.3 MPa MOPD: 3.6 MPa
Electronic Expansion Valve		DPF (T51) 1.0-3.2 DPF (S03) 4.0-7.5	120°C	R515B, R245fa, R1233zd (E), R134a, R123, R32	R515B, R245fa	liquid line	throttling	20-65KW@ R515B	Adopt high temperature resistant parts MWP: 4.5 MPa MOPD: 3.0 MPa*
Electronic Expansion Valve		VPF12.5-VPF400 *must select high temperature models	130°C (VPF12.5-25) 120°C (VPF50-400)	R515B, R245fa, R1233zd (E), R134a, R123, R32	R515B	liquid line	throttling	30-98KW@ R515B	Adopt high temperature resistant parts MWP: 4.5 MPa MOPD: 3.5 MPa*
Electric Ball Valve		EBV03-EBV09 connection: 3/8"-1-1/8"	120°C	R515B, R245fa, R134a, R123, R32	R515B, R245fa	before the liquied line expansion valve or directly used as throttle valve	liquid cutoff flow regulation	20-65KW@ R515B	MWP: 4.3 MPa MOPD: 3.3 MPa
Solenoid Valve		HDF2-HDF25 (connection: 1/4" — 1-1/8") MDF25 (connection: 1-1/8")	160°C	R515B, R245fa, R1233zd (E), R134a, R123, R32	R515B, R245fa	exhausting side oil line, spray line	ejection oil return, spray cooling	51-300KW@ R515B	Piston design, high temperature resistance MWP: 4.5MPa MOPD: 1-1.5MPa
Plate Heat Exchanger		S6-S60B	200°C	R515B, R245fa, R1233zd (E), R134a, R123, R32	R515B, R245fa, R1233zd (E)	oil line	oil cooler	1.2-60KW@ R515B	MWP: 4.9MPa
Pressure Transducer		high pressure YCQB05 low pressure YCQB02 *ambient temperature ≤ 80°C	150°C	R515B, R245fa, R1233zd (E), R134a, R123, R32	R515B, R245fa, R1233zd (E)	exhausting side after the oil separator is recommended suction line	system control	no relation with the system capacity	Voltage type output 0-5MPa/0-2MPa (range can be) MWP: 5MPa
Check Valve		CCV17-CCV32 (connection: 1/2"-1-1/8")	150°C	R515B, R245fa, R134a, R123, R32	R515B, R245fa, R1233zd (E)	exhausting side	prevent refrigerant reflux	2.3-130KW@ R515B	Metal diaphragm design High temperature resistance, free installation angle MWP: 4.8MPa
Filter Drier		DTG-B (connection: 3/8"-1-1/8")	120°C	R515B, R245fa, R134a, R123, R32	R515B, R245fa	liquid line	drying filtration	20-65KW@ R515B	Water absorption and impurity filtration capacity is 20-40% higher than that of peers
Manual Ball Valve		SBV10-79 connection: 3/8"-1-1/8"	120°C	R515B, R245fa, R1233zd (E), R134a, R123, R32	R515B, R245fa	liquid line, before and after the filter	overhaul and maintenance filter replacement	20-1000KW@ R515B	High temperature sealing material MWP: 4.5MPa
Manual Ball Valve		RBV10-54 connection: 3/8"-2-1/8" *without charging end	160°C	R515B, R245fa, R1233zd (E), R134a, R123, R32	R515B, R245fa, R1233zd (E)	exhausting side liquid line, before and after the filter	overhaul and maintenance filter replacement	20-1000KW@ R515B	Sealing with patented graphite Resistance to ultra-high temperature, high wear resistance MWP: 4.5MPa
Ejector		connection: 12.7mm	150°C	R515B, R245fa, R1233zd (E), R134a, R123, R32	R515B, R245fa, R1233zd (E)	oil line	full liquid evaporator oil return	3-150KW@ R515B	All metal design
Pressure Switch		high and low pressure controller PSV15	150°C	R515B, R245fa, R1233zd (E), R134a, R123	R515B, R245fa, R1233zd (E)	system high and low pressure	pressure protection	no relation with the system capacity	High lifetime, high accuracy, good adjustability MWP: 3.5MPa

DPF-TS/S03 Series

Electronic Expansion Valve

DPF-TS/S03 series electronic expansion valve is mainly used in the liquid pipeline position of high temperature heat pump system to realize the automatic adjustment of refrigerant flow, so that the system can operate under the best working conditions, and achieve rapid cooling or heating, accurate control and energy saving purposes.



FEATURES

- Adopting high temperature resistance nuts internally
- Smaller installation space: low height, small volume, light weight
- Optimized flow path design for noise reduction
- Fast operation, energy saving
- Two-way flow, applicable for reversible systems such as heat pump
- Compatible with Sanhua SEC series controller

GENERAL SPECIFICATIONS

- Applicable refrigerants: R515B, R245fa+ refrigeration oil and other HCFC, HFC, HC, HFO refrigerants
- Capacity range: 20~65KW@R515B
- Medium temperature: -60°C ~+120°C (duty cycle rate below 50%)
- Ambient temperature: -30°C ~+70°C (duty cycle rate below 50%)
- MWP: 4.5Mpa
- MOPD: 3.0Mpa
- 500 steps (full stroke); 32±20 opening pulse
- Certifications: UL&TUV and declaration according to LVD or PED
- Installation position:
 - Coil up, valve body rotor central axis perpendicular to the horizontal plane, deviation within 15°
 - Inlet connection preferably horizontal, outlet preferably downwards

ELECTRICAL PARAMETERS

- Rated voltage: 12V DC (±10%), rectangular wave
- Actuating mode: 4-phase 8-step permanent magnet stepping motor of direct-acting type
- Excitation mode: 1~2 phase excitation, unipolar actuation
- Excitation rate: 30 pps-40 pps
- Activation of self-holding mechanism: maintain excitation in stop position min. 0.1s~1.0sec.
- Min. Motion time from completely open to completely closed: 13s (40pps)
- Coil current: DPF (TS1)1.0-3.2, 260mA/phase (20°C) DPF (S03)4.0-7.5: 375mA/phase (20°C)
- Coil resistance: DPF (TS1)1.0-3.2, 46±3.7Ω/phase (20°C) DPF (S03)4.0-7.5: 32±3.2Ω/phase (20°C)
- Insulation class of coil: E
- Protection class: IP67

DPF-TS/S03 Series

Electronic Expansion Valve



TECHNICAL PARAMETERS

Condition 1: condensing temperature $T_c=80^{\circ}\text{C}$; evaporating temperature $T_e=45^{\circ}\text{C}$; supercooling $SC=15\text{K}$; superheat $SH=8\text{K}$

Series	Nominal Cooling Capacity [kW]						Kv [m ³ /h]	MAX.Oper. Press. [MPa]	MOPD Direct [MPa]	MOPD Rev. [MPa]	Model
	R134a	R142b	R515B	R245fa	R1233zd (E)	R123					
DPF1.0	4.0	3.5	3.2	2.9	2.6	2.3	0.03	4.2	3.5	≥2.5	DPF (TS1)1.0C-600
DPF1.3	5.6	4.9	4.5	4.1	3.7	3.2	0.05				DPF (TS1)1.3C-600
DPF1.65	9.4	8.3	7.6	6.9	6.3	5.4	0.08				DPF (TS1)1.65C-600
DPF1.8	11.2	9.9	9.0	8.2	7.4	6.4	0.1				DPF (TS1)1.8C-600
DPF2.0	13.9	12.1	11.1	10.2	9.2	7.9	0.16				DPF (TS1)2.0C-600
DPF2.2	14.9	13.1	12.0	10.9	9.9	8.5	0.2				DPF (TS1)2.2C-600
DPF2.4	17.5	15.5	14.1	12.9	11.7	10.1	0.23			DPF (TS1)2.4C-600	
DPF3.0	29.0	25.6	23.3	21.3	19.3	16.5	0.39			≥1.5	DPF (TS1)3.0C-600
DPF3.2	32.0	28.2	26.7	23.4	21.3	18.2	0.43				DPF (TS1)3.2C-600
DPF4.0	53.2	47.0	42.7	39.0	35.4	30.3	0.5			4.5	≥0.7
DPF4.5	71.2	62.8	57.2	52.2	47.3	40.5	0.7	DPF (S03)4.5C-01			
DPF5.5	82.4	72.7	66.2	60.4	54.8	46.9	0.9	DPF (S03)5.5C-01			
DPF6.5	100.2	88.5	80.5	73.5	66.6	57.1	1.1	DPF (S03)6.5C-02			
DPF7.0	111.1	98.1	89.3	81.5	73.9	63.3	1.22	3.0	≥0.7		DPF (S03)7.0C-01
DPF7.5	123.0	108.6	98.8	90.2	81.8	70.1	1.35		≥0.6		DPF (S03)7.5C-01

Condition 2: condensing temperature $T_c=100^{\circ}\text{C}$; evaporating temperature $T_e=45^{\circ}\text{C}$; supercooling $SC=15\text{K}$; superheat $SH=8\text{K}$

Series	Nominal Cooling Capacity [kW]					Kv [m ³ /h]	MAX.Oper. Press. [MPa]	MOPD Direct [MPa]	MOPD Rev. [MPa]	Model
	R142b	R515B	R245fa	R1233zd (E)	R123					
DPF1.0	3.8	3.1	3.3	3.0	2.6	0.03	4.2	3.5	≥2.5	DPF (TS1)1.0C-600
DPF1.3	5.4	4.4	4.6	4.2	3.7	0.05				DPF (TS1)1.3C-600
DPF1.65	9.1	7.4	7.7	7.1	6.2	0.08				DPF (TS1)1.65C-600
DPF1.8	10.8	8.8	9.2	8.4	7.4	0.1				DPF (TS1)1.8C-600
DPF2.0	13.4	10.9	11.3	10.4	8.1	0.16				DPF (TS1)2.0C-600
DPF2.2	14.4	11.7	12.2	11.2	9.8	0.2				DPF (TS1)2.2C-600
DPF2.4	17.0	13.8	14.3	13.2	11.6	0.23			DPF (TS1)2.4C-600	
DPF3.0	28.1	22.8	23.8	21.9	19.2	0.39			≥1.5	DPF (TS1)3.0C-600
DPF3.2	30.9	25.1	26.2	24.1	21.1	0.43				DPF (TS1)3.2C-600
DPF4.0	51.5	41.8	43.5	40.0	35.1	0.5			4.5	≥0.7
DPF4.5	68.8	55.9	58.2	53.6	47.0	0.7	DPF (S03)4.5C-01			
DPF5.5	79.7	64.7	67.4	62.0	54.4	0.9	DPF (S03)5.5C-01			
DPF6.5	96.9	78.7	82	75.4	66.1	1.1	DPF (S03)6.5C-02			
DPF7.0	107.5	87.2	90.9	83.7	73.4	1.22	3.0	≥0.7		DPF (S03)7.0C-01
DPF7.5	119.0	96.5	100.6	92.6	81.2	1.35		≥0.6		DPF (S03)7.5C-01

DPF-TS/S03 Series Electronic Expansion Valve



FLOW CHARACTERISTIC

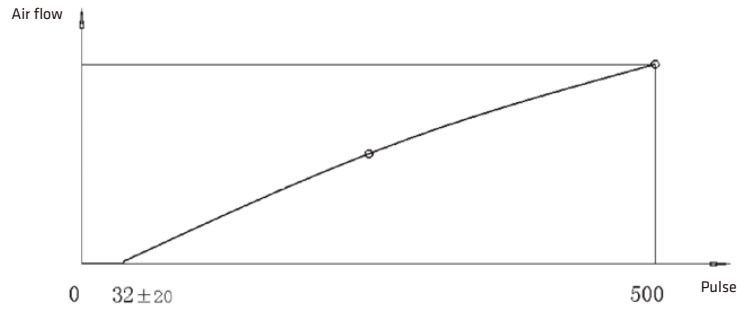

DIMENSIONS

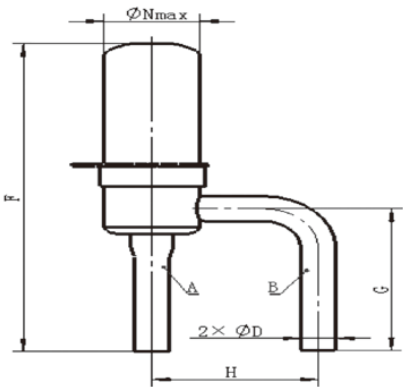

DPF (TS1) 1.0~2.4

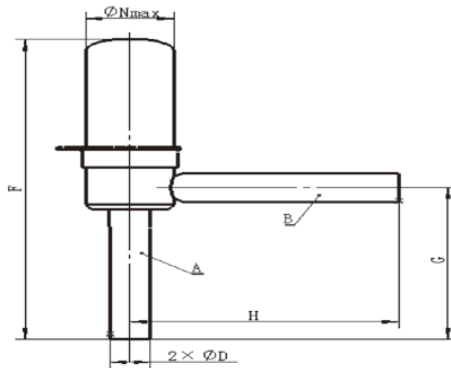

DPF (TS1) 3.0~3.2

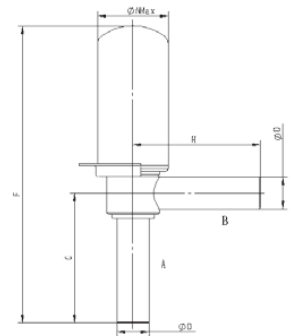

DPF (S03) 4.0~7.5

Series	Coil Series	Dimensions [mm]				
		F	G	H	ØD Connections	ØN
DPF 1.0~2.4	PQM10	78	36	30	6.35	17.35
DPF 3.0~3.2	PQ M10	85	43	53	7.94	17.35
DPF (S03) 4.0~7.5	PQ M03	148	64.7	63.4	15.88	35.3

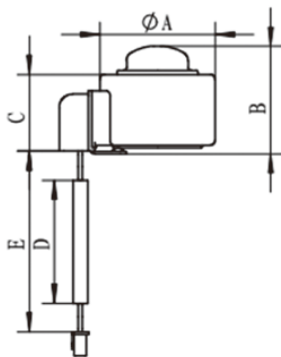

Valve Series	Dimensions [mm]					Terminal	Coil Model
	ØA	B	C	Cable length	E		
DPF (TS1) 1.0~3.2	38.5	35.8	25.6	700	600	XHP-5	PQ-M10012-001059
DPF (TS1) 1.0~3.2	38.5	35.8	25.6	1500	1400	XHP-5	PQ-M10012-001016
DPF (TS1) 1.0~3.2	38.5	35.8	25.6	2000	1800	XHP-5	PQ-M10012-001002
DPF (S03) 4.0~7.5	67.5	74.4	33.3	2000	1900	XHP-5	PQ-M03012-001004

VPF Series

Electronic Expansion Valve

VPF series electronic expansion valves are designed for commercial and industrial applications, can be used in high temperature heat pump system. The valve controls the automatic adjustment of refrigerant flow rate and makes the system work under optimized conditions for the purpose of fast cooling or heating, precise temperature control and energy saving. The VPF flow curve is designed bi-directional, so that the flow rate can be accurately controlled under both cooling and heating conditions.



FEATURES

- Energy saving thanks to very precise capacity control: up to 3800 steps
- Compact design, smaller installation space
- With two-way cutoff function, internal tightness like a solenoid valve
- Applicable for reversible systems like heat pumps: bidirectional flow
- All stainless steel and corrosion resistance design, perfect sealing, long lifetime, higher reliability
- Without integrated sight glass

GENERAL SPECIFICATION

- Applicable refrigerants: R515B, R245fa+, R1233zd (E), refrigeration oil and other HCFC, HFC, HC, HFO refrigerants, cannot used for oil-free systems
- Capacity range: 30~985KW@R515B
- Full stroke:
 - 2600 steps: VPF12.5, VPF 25, VPF50
 - 3500 steps: VPF 100
 - 3800 steps: VPF 150, VPF250, VPF400
- Valve opening stroke:
 - 110 steps: VPF12.5, VPF25
 - 165 steps: VPF50~VPF400
- Medium temperature: -40°C /+130°C (VPF12.5-25); -40°C /+120°C (VPF50-400) (duty cycle rate below 50%)
- Ambient temperature: -40°C /+70°C (duty cycle rate below 50%)
- Max. Operating pressure: VPF12.5~VPF150: 5.0Mpa; VPF250~VPF400: 4.5Mpa
- Max. OPD: VPF12.5~VPF150: 3.5Mpa (forward and reverse); VPF250~VPF400: 3.5Mpa (unidirection)
- Installation position:
 - The main flow of refrigerant corresponds to the arrow
 - Installation in horizontal and vertical pipes possible
 - Installation position in horizontal lines with stepper motor preferably upwards
- Certifications: UL&TUV, declaration according to PED and EAC

VPF Series

Electronic Expansion Valve



ELECTRICAL PARAMETERS

- Actuating mode: 2-phase 4-step permanent magnet stepping motor
- Excitation mode: 2 phase excitation, bi-pole actuation
- Excitation rate: 300 pps (current drive)
- Motion time from completely open to completely closed (current drive): - VPF12.5~VPF50: 8.7s
- VPF100: 11.7s
- VPF150~400: 12.7s
- Motor rated current: 100mA RMS/phase (during normal control)
- Motor peak current: 140mA/phase (during reset operation)
- Coil resistance: $52 \pm 5.2\Omega$ /coil (20°C)
- Insulation class of coil: E
- Protection class: IP67

TECHNICAL PARAMETERS

Series	Connections Ød ODF		Valve Shape	Sight glass 1)	Kv 2)	Model 3)
	Inlet A x Outlet B					
	[inch]	[mm]			[m ³ /h]	
VPF 12.5	5/8 x 5/8	16 × 16	straight	-	0.8	VPF12.5H72
VPF 25	7/8 x 7/8	22 × 22	straight	-	1.3	VPF25H73
VPF 50	7/8 x 7/8	22 x 22	straight	-	2.4	VPF50H71
VPF 100	1-3/8 x 1-3/8	35 x 35	straight	-	4.0	VPF100H73
VPF 150	1-5/8 x 1-5/8	-	L shape	yes	7.7	VPF150H72
VPF 250	1-5/8 x 1-5/8	-	straight	yes	14.0	VPF250H47
VPF 400	2-1/8 x 2-1/8	54 x 54	straight	yes	17.0	VPF400H33

Note: 1) VPF12.5-100 without sight glass; VPF150-400 with sight glass but without test paper

2) Kv values valid for the flow direction inlet A to outlet B

3) Product model: only the valve body is included, please purchase the cables separately

COOLING CAPACITY

Condition 1: condensing temperature $T_c=80^\circ\text{C}$; evaporating temperature $T_e=45^\circ\text{C}$; supercooling $SC=15\text{K}$; superheat $SH=8\text{K}$

Series	Full Stroke	Nominal Cooling Capacity [kW]					
		R134a	R142b	R515B	R245fa	R1233zd (E)	R123
VPF 12.5	2600	73.1	64.5	58.7	53.6	48.6	41.6
VPF 25	2600	151.8	134.0	121.9	111.3	100.9	86.5
VPF 50	2600	305.0	269.4	245.1	223.7	202.9	173.8
VPF 100	3500	433.2	382.6	348.1	317.7	288.1	246.8
VPF 150	3800	753.9	665.7	605.7	552.78	501.4	429.4
VPF 250	3800	1208.3	1067.0	970.8	886.1	803.6	688.3
VPF 400	3800	2025.3	1788.4	1627.2	1485.1	1347.0	1153.7

VPF Series

Electronic Expansion Valve



Condition 2: condensing temperature $T_c=100^{\circ}\text{C}$; evaporating temperature $T_e=45^{\circ}\text{C}$; supercooling $SC=15\text{K}$; superheat $SH=8\text{K}$

Series	Full Stroke	Nominal Cooling Capacity [kW]				
		R142b	R515B	R245fa	R1233zd (E)	R123
VPF 12.5	2600	70.7	53.38	59.8	55.0	48.2
VPF 25	2600	146.8	119.1	124.2	114.2	100.2
VPF 50	2600	295.0	239.5	249.6	229.6	201.4
VPF 100	3500	419.0	340.0	354.5	326.1	286.0
VPF 150	3800	729.2	591.8	616.8	567.5	497.6
VPF 250	3800	1168.8	948.6	988.7	909.5	797.6
VPF 400	3800	1959.1	1589.9	1657.2	1524.5	1337.0

ACCESSORIES: connection cable

Model	Cable Length [m]
Y02A	2
Y08A	8

Note: 1) The cable is used to connect the valve body stepper motor interface and the controller
 2)The protection class of VPF cable is IP67

Excitation way and valve-on and valve-off connection graph

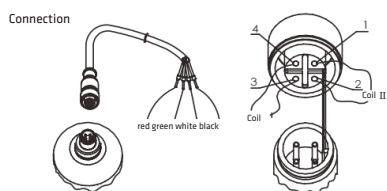

	Step sequence	First winding		Second winding		
		Red	Green	White	Black	
Close valve ↑	1	+	-	+	-	Open valve ↓
	2	+	-	-	+	
	3	-	+	-	+	
	4	-	+	+	-	
	1	+	-	+	-	

CCV series

Magnetic Type of Check Valve

CCV series diaphragm check valve is used in high temperature heat pump system. It can be installed in high temperature and high pressure parts such as the compressor exhaust side, and can also be applied to the suction side of the compressor. The main function is to control the one-way flow of refrigerant and prevent reverse flow.



FEATURES

- Low pressure drops and low internal leakage
- Size 1/4" -3/4" are copper valve body, and size no less 7/8" are stainless steel valve body (with copper joints, welding protection is not required)
- Built-in filter
- All-metal design, strong refrigerant compatibility

GENERAL SPECIFICATION

- Applicable for R515B, R245fa, R1233zd (E) and all common HCFC, HFC, HFO refrigerants
- Medium temperature TS min. /max.: -40°C / +150°C
- Max. operating pressure PS: 4.9 MPa (49 bar)
- Installation position:
 - Flow direction corresponds to the arrow
 - CCV can be installed in any position and direction in the system
- Declaration according to PED

CCV series

Magnetic Type of Check Valve



TECHNICAL PARAMETER

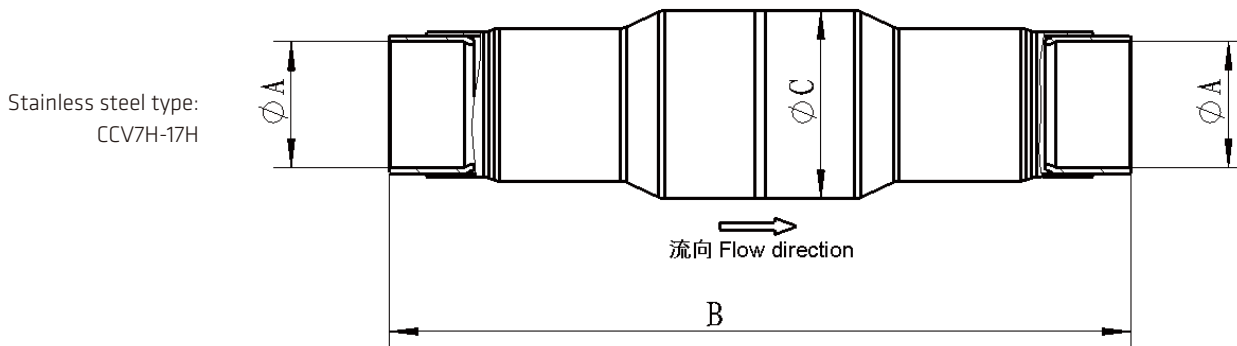
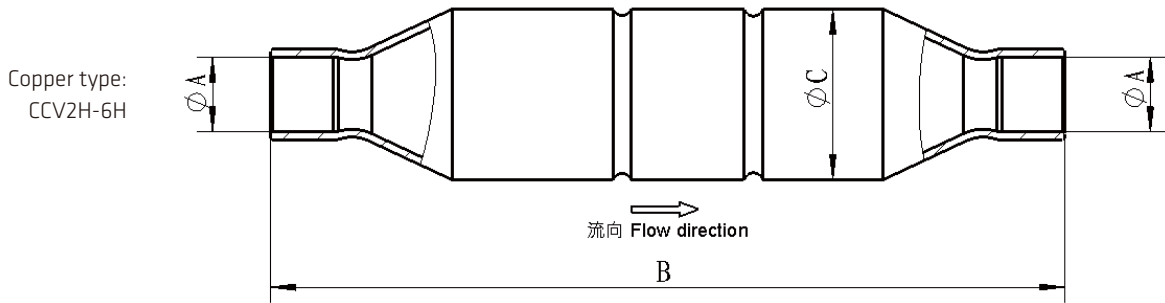

Series	Valve Body Material	Connection ODF		Model name	Kv [m ³ /h]	Min. OPD (Air) [kPa]	B [mm]	ØC [mm]
		Ø A (ID)						
		[in]	[mm]					
CCV4H	Copper	1/2	-	CCV4H05	2.7	10	127	(28)
CCV5H	Copper	5/8	16	CCV5H06	2.9	10	127	(28)
CCV6H	Copper	3/4	-	CCV6H05	2.9	10	127	(28)
CCV7H	Stainless steel	7/8	22	CCV7H01	6.5	10	178	(35.5)
CCV9H	Stainless steel	1-1/8	-	CCV9H01	11.4	10	212	(45)

SBV Sereis

Ball Valve

SBV series ball valve is suitable for high temperature heat pump system liquid line where is before and after the filter, through the operation of the valve stem to open and cut off the internal flow path. It can also be used as service valve for vacuum pumping and refrigerant injection etc.

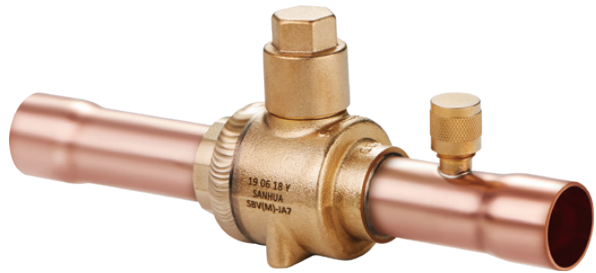

FEATURES

- Straightway type structure, the full port and necking valves are optional
- Valve body and valve seat with welding structure, with high product reliability
- Bi-directional flow
- Rotation stop ring assembly is built in the valve (no less than 1-1/8") for anti-rotation
- Special sealing materials to prevent internal leakage

GENERAL SPECIFICATION

- Applicable for R515B, R245fa and all common HCFC, HFC, HFO refrigerants
- Medium temperature TS min. /max.: -40°C / +120°C (+120°C - +150°C for short term use)
- Max. operating pressure PS: 4.9 MPa (49 bar)
- Installation position: liquid, suction and discharge line
- Certifications: UL/CUL and PED declaration

SBV Sereis

Ball Valve



TECHNICAL PARAMETER

1. SBV standard model (Full port)

Series	Connection Ø d ODF		Kv [m ³ /h]	Valve model	
	[inch]	[mm]		Without Access Fitting	With Access Fitting
SBV 10	3/8	-	5.5	SBV03-019T	SBV03-319T
SBV 10	-	10	5.5	SBV03-020T	SBV03-320T
SBV 12	-	12	7.3	SBV04-020T	SBV04-320T
SBV 12	1/2	-	7.3	SBV04-019T	SBV04-319T
SBV 15	-	15	13.8	SBV (M)-A5YHSY-2-SA	SBV (M)-JA5YHSY-2-SA
SBV 16	5/8	16	13.8	SBV (M)-A5YHSY-1-SA	SBV (M)-JA5YHSY-1-SA
SBV 18	-	18	20.6	SBV (M)-A6YHSY-2-SA	SBV (M)-JA6YHSY-2-SA
SBV 18	3/4	19	20.6	SBV (M)-A6YHSY-1-SA	SBV (M)-JA6YHSY-1-SA
SBV 22	7/8	22	29	SBV (M)-A7YHSY-1-SA	SBV (M)-JA7YHSY-1-SA
SBV 28	-	28	54.3	SBV (M)-A9YHSY-2-SA	SBV (M)-JA9YHSY-2-SA
SBV 28	1-1/8	-	54.3	SBV (M)-A9YHSY-1-SA	SBV (M)-JA9YHSY-1-SA
SBV 35	1-3/8	35	85.5	SBV (M)-A11YHSY-1-SA	SBV (M)-JA11YHSY-1-SA
SBV 42	1-5/8	-	133.7	SBV (M)-A13YHSY-2-SA	SBV (M)-JA13YHSY-2-SA
SBV 42	-	42	133.7	SBV (M)-A13YHSY-1-SA	SBV (M)-JA13YHSY-1-SA
SBV 54	2-1/8	54	225	SBV (M)-A17YHSY-1-SA	SBV (M)-JA17YHSY-1-SA
SBV 64	-	64	225	SBV (M)-A19YHSY-1-SA	SBV (M)-JA19YHSY-1-SA
SBV 67	2-5/8	-	380	SBV (M)-A21YHSY-2-SA	SBV (M)-JA21YHSY-2-SA
SBV 79	3-1/8	79	530	SBV (M)-A25YHSY-2-SA	SBV (M)-JA25YHSY-2-SA

2. SBV standard model (Necking)

Series	Connection Ø d ODF		Kv [m ³ /h]	Valve model	
	[inch]	[mm]		Without Access Fitting	With Access Fitting
SBV 16	5/8	16	7.3	SBV05-601	SBV05-801
SBV 18	-	18	13.8	SBV06-602	SBV06-802
SBV 18	3/4	-	13.8	SBV06-601	SBV06-801
SBV 22	7/8	22	13.8	SBV07-601	SBV07-801
SBV 28	-	28	29	SBV09-602	SBV09-802
SBV 28	1-1/8	-	29	SBV09-601	SBV09-801
SBV 35	1-3/8	35	54.3	SBV11-601	SBV11-801
SBV 42	1-5/8	-	85.5	SBV13-601	SBV13-801
SBV 42	-	42	85.5	SBV13-602	SBV13-802
SBV 54	2-1/8	54	133.7	SBV17-601	SBV17-801
SBV 67	2-5/8	-	225	SBV21-601	-
SBV 79	3-1/8	80	380	SBV25-601	-

RBV-R Series

Ball Valve

The RBV-R series ball valve is suitable for the exhaust side of the high temperature heat pump or before and after the filter of liquid line, open and cut off the internal flow path by operating the valve stem. It can also be used as service valve for vacuum pumping and refrigerant injection etc.

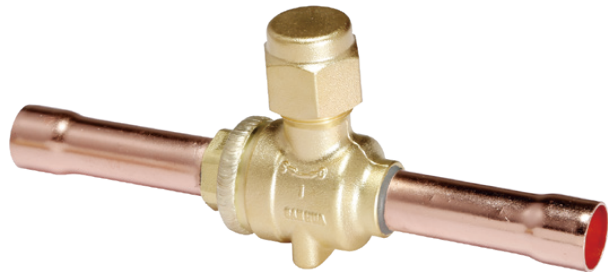

FEATURES

- Straightway type structure, the full port and low pressure drop
- Valve body and valve seat with welding structure, with high product reliability
- Bi-directional flow
- Rotation stop ring assembly is built in the valve for anti-rotation
- Special sealing materials to prevent internal leakage

GENERAL SPECIFICATION

- Applicable for R515B, R245fa, R1233zd (E) and all common HCFC, HFC, HFO refrigerants
- Medium temperature TS min. /max.: -40°C / +160°C
- Max. operating pressure PS: 4.9 MPa (49 bar)
- Installation position: liquid, suction and discharge line
- The RBV-R series is without access fitting
- Certifications: UL/CUL and PED declaration

RBV-R Sereis

Ball Valve



TECHNICAL PARAMETER

Series	Connection Ø d ODF		Kv	Valve model
	[inch]	[mm]	[m ³ /h]	Without Access Fitting
RBV 10	3/8	-	5.5	RBV03-003R
RBV 10	-	10	5.5	RBV03-004R
RBV 12	1/2	-	7.3	RBV04-003R
RBV 12	-	12	7.3	RBV04-004R
RBV 16	5/8	16	13.8	RBV05-003R
RBV 18	3/4	19	20.6	RBV06-003R
RBV 22	7/8	22	29.0	RBV07-003R
RBV 28	1-1/8	-	54.3	RBV09-003R
RBV 28	-	28	54.3	RBV09-004R
RBV 35	1-3/8	35	85.5	RBV11-003R
RBV 42	1-5/8	-	133.7	RBV13-003R
RBV 42	-	42	133.7	RBV13-004R
RBV 54	2-1/8	54	225.0	RBV17-003R

HDF/MDF Series Solenoid valve

This series solenoid valve is suitable for medium on-off control of high temperature heat pump system.



FEATURES

- Coil: Low power consumption and high reliability, and it's double sealed to reach IP67
- Special piston structure, and excellent anti-impurity ability
- Detachable structure for easy maintenance (Only HDF series)
- It can be used in oil circuit

GENERAL SPECIFICATION

- Applicable for R515B, R245fa, R1233zd (E) and all common HCFC, HFC, HFO refrigerants
- Ambient temperature TS min. /max.: -40°C / +60°C (The Max. T of HDF19, 25 and MDF25 is +55°C)
- Relative humidity: Less than 95%
- Installation position and direction: Vertical and horizontal are both ok, suction/ discharge port and liquid line

HDF/MDF Sereis

Solenoid valve



TECHNICAL PARAMETER

Valve model	Operation type	Kv	Connection	Max. OP	Min. OP	Max. OPD	Medium Temperature
				[MPa]	[MPa]	(AC coil) [MPa]	
HDF2H81K	NC	0.12	3/8	4.5	0	Air: 1.5MPa Liquid: 1.5MPa Oil: 1MPa	-40°C ~+160°C
HDF2H82K		0.12	1/4	4.5	0		
HDF3H81K		0.26	1/4	4.5	0		
HDF3H82K		0.26	3/8	4.5	0		
HDF3H83K		0.26	1/2	4.5	0		
HDF5H81K		0.5	3/8	4.5	0.007		-40°C ~+150°C
HDF5H82K		0.5	1/2	4.5	0.007		
HDF5H83K		0.5	1/4	4.5	0.007		
HDF6H81K		0.8	1/2	4.5	0.007		
HDF6H82K		0.8	3/8	4.5	0.007		
HDF9H81K		1.3	5/8	4.5	0.007		-40°C ~+160°C
HDF9H82K		1.3	1/2	4.5	0.007		
HDF9H83K		1.3	3/8	4.5	0.007		
HDF9H84K		1.3	3/8	4.5	0.007		
HDF10H82K		1.9	1/2	4.5	0.007		
HDF10H81K		1.9	5/8	4.5	0.007		
HDF15H81K		2.5	5/8	4.5	0.007		
HDF15H86K		2.5	3/4	4.5	0.007		
HDF15H82K		2.5	7/8	4.5	0.007		
HDF19H31K		4.3	7/8	3.2	0.014		
HDF25H32K	7.3	11/8	3.2	0.014	-40°C ~+140°C		
MDF-B03-25H008	10	11/8	4.5	0.02			

MATCHING COIL

Matching Valve	Rated Voltage	Voltage fluctuation	Coil type	Power (50/60Hz)	Insulation class	Class of protection	Coil Model
	[V]			[W]			
HDF Series	AC24	-15% +10%	DIN Connector	10/9	F	IP67	MQ-A03024-001001
	AC110 ~ 120			10/9			MQ-A0311A-001001
	AC220 ~ 240			10/9			MQ-A0322G-001001

Matching Valve	Rated Voltage	Voltage fluctuation	Coil type	Power (50/60Hz)	Insulation class	Class of protection	Coil Model
	[V]			[W]			
MDF Series	AC24	-15% +10%	DIN Connector	10.5/8.5	F	IP67	MQ-A03024-000001
	AC110 ~ 120			12/10			MQ-A0311A-000001
	AC220 ~ 240			12/10			MQ-A0322G-000001

SHF-R Series

4 Way Reversing Valve

SHF-R series four-way reversing valve can withstand high temperature up to 150 ° C, suitable for high temperature Heat pump system to realize switching between cooling mode and heating mode by changing the flow path of refrigerant.



FEATURES

- High temperature resistance, suitable for high temperature heat pump systems
- Wide application range, suitable for nominal capacity from 20.4 to 81.6kW (@ R515B)

GENERAL SPECIFICATIONS

- Applicable refrigerants: R515B, R245fa, R1233zd (E), R134a, R123, R32 and other HCFC, HFC, HC, HFO refrigerants
- Applicable medium temperature: -30 °C ~+150 °C
- Max working pressure: 4.3MPa
- Certification: UL & CUL, VDE, CQC, compliant with LVD or PED directives

SHF-R Sereis

4 Way Reversing Valve



TECHNICAL PARAMETERS

Valve series	Fixed/ Inverter AC	Connections ODF		Max. Working pressure	OPD		Medium temperature	Valve model
		ØD	ØE, S, C		Max.	Min.		
		[inch]	[inch]	[MPa]	[MPa]	[MPa]	[°C]	
SHF35R	General	1/2	7/8	4.3	3.6	0.3	-30/150	SHF-35R-47
SHF35R	General	5/8	7/8	4.3	3.6	0.3	-30/150	SHF-35R-57
SHF35R	General	5/8	1-1/8	4.3	3.6	0.3	-30/150	SHF-35R-59
SHF35R	General	3/4	7/8	4.3	3.6	0.3	-30/150	SHF-35R-67
SHF35R	General	3/4	1-1/8	4.3	3.6	0.3	-30/150	SHF-35R-69
SHF35R	General	7/8	1-1/8	4.3	3.6	0.3	-30/150	SHF-35R-79
SHF50R	General	7/8	1-1/8	4.3	3.6	0.3	-30/150	SHF-50R-79
SHF70R	General	1	1-1/4	4.3	3.6	0.3	-30/150	SHF (L)-70R-810
SHF70R	General	1	1-1/4	4.3	3.6	0.3	-30/150	SHF (L)-70R-810-01
SHF70R	General	1-1/8	1-3/8	4.3	3.6	0.3	-30/150	SHF (L)-70R-911
SHF70R	General	1-1/8	1-3/8	4.3	3.6	0.3	-30/150	SHF (L)-70R-911-01
SHF70R	General	1-1/8	1-5/8	4.3	3.6	0.3	-30/150	SHF (L)-70R-913-05
SHF70R	General	1-1/8	1-5/8	4.3	3.6	0.3	-30/150	SHF (L)-70R-913-03
SHF100R	General	1-1/8	1-3/8	4.3	3.6	0.3	-30/150	SHF (L)-100R-911
SHF100R	General	1-1/8	1-3/8	4.3	3.6	0.3	-30/150	SHF (L)-100R-911-01
SHF100R	General	1-1/8	1-5/8	4.3	3.6	0.3	-30/150	SHF (L)-100R-913
SHF100R	General	1-1/8	1-5/8	4.3	3.6	0.3	-30/150	SHF (L)-100R-913-01
SHF100R	General	1-1/4	1-1/2	4.3	3.6	0.3	-30/150	SHF (L)-100R-1012
SHF100R	General	1-1/4	1-1/2	4.3	3.6	0.3	-30/150	SHF (L)-100R-1012-01
SHF100R	General	1-1/4	1-5/8	4.3	3.6	0.3	-30/150	SHF (L)-100R-1013
SHF100R	General	1-1/4	1-5/8	4.3	3.6	0.3	-30/150	SHF (L)-100R-1013-01
SHF140R	General	1-3/8	1-5/8	4.3	3.6	0.3	-30/150	SHF (L)-140R-1113
SHF140R	General	1-1/2	1-5/8	4.3	3.6	0.3	-30/150	SHF (L)-140R-1213
SHF140R	General	1-1/2	1-3/4	4.3	3.6	0.3	-30/150	SHF (L)-140R-1214
SHF140R	General	1-5/8	1-5/8	4.3	3.6	0.3	-30/150	SHF (L)-140R-1313

COIL CHARACTERISTICS

Winding code*	Rated voltage	Connection type	Cable length	Power consumption		Protection class	Insulation class	Max. Op. Temp.	Coil model
				50/60Hz	DC				
	[V]		[inch]	[W]	[W]	[-]	[-]	[°C]	
SHF-4-10L3	AC220-240	Lead wires	500	4.5/3.5W		IP54	B	130	SQ-A3722G-000001
SHF-4-10L4	AC110-120	Lead wires	500	4.5/3.5W		IP54	B	130	SQ-A2511A-001020
SHF-4-10L5	AC24	Lead wires	500	4.5/3.5W		IP54	B	130	SQ-A25024-001040
SHF-4-10L3	AC220-240	Lead wires	1500	4.5/3.5W		IP54	B	130	SQ-A3722G-000057
SHF-4-10L4	AC110-120	Lead wires	1500	4.5/3.5W		IP54	B	130	SQ-A2511A-005052
SHF-4-10L5	AC24	Lead wires	1500	4.5/3.5W		IP54	B	130	SQ-A25024-001046
SHF-4-10FA8	DC12	Spade	-	-	10	IP00	F	155	SQ-D44012-000001
SHF-4-10FA9	DC24	Spade	-	-	10	IP00	F	155	SQ-D44024-000001

SHF-R Sereis

4 Way Reversing Valve



CAPACITY SELECTION TABLE

Valve series	Nominal cooling capacity (High temperature drying) [KW]						Nominal cooling capacity (High temperature hot water) [KW]						Nominal cooling capacity (High temperature vapor) [KW]			
	R245fa		R134a		R123		R245fa		R134a		R123		R245fa		R123	
	ΔP : 0.1 bar	ΔP : 0.2 bar	ΔP : 0.1 bar	ΔP : 0.2 bar	ΔP : 0.1 bar	ΔP : 0.2 bar	ΔP : 0.1 bar	ΔP : 0.2 bar	ΔP : 0.1 bar	ΔP : 0.2 bar	ΔP : 0.1 bar	ΔP : 0.2 bar	ΔP : 0.1 bar	ΔP : 0.2 bar	ΔP : 0.1 bar	ΔP : 0.2 bar
SHF35R	26.6	37.7	42.3	59.8	20.5	29.0	21.7	30.7	31.7	44.9	17.5	24.7	12.4	17.6	11.9	16.8
SHF50R	36.4	51.5	57.8	81.8	28.1	39.7	29.7	42.0	43.4	61.4	23.9	33.8	17.0	24.0	16.3	23.0
SHF70R	48.2	68.1	76.5	108.2	37.1	52.5	39.3	55.5	57.4	81.2	31.6	44.7	22.5	31.8	21.5	30.4
SHF100R	70.6	99.8	112.1	158.5	54.4	77.0	57.6	81.4	84.1	119.0	46.4	65.6	32.9	46.6	31.5	44.6
SHF140R	122.8	173.7	195.0	275.7	94.7	133.9	100.1	141.6	146.3	206.9	80.6	114.0	57.3	81.0	54.9	77.6

Note: 1. ΔP represents the pressure drop from $\emptyset C$ to $\emptyset S$ or from $\emptyset E$ to $\emptyset S$;

2. The selection capacity of the four-way valve for R32 systems should be $\geq 60\%$. It is not recommended to use the four-way valve in systems with a capacity less than 60% of the nominal capacity. When used in R32 systems, it is essential to ensure the reliability of low-pressure commutation under extreme conditions.

额定工况	High temperature drying	High temperature hot water	High temperature vapor
Evaporating temperature to (°C)	45	45	45
Condensing temperature t_c (°C)	80	100	135
Superheat Δt_{sc} (K)	8	8	8
Subcooling Δt_{sr} (K)	15	15	15

EBV Series

Electric Ball Valve

EBV electric ball valve can adjust the refrigerant flow and cut off the refrigerant passage according to the system operating conditions, and is suitable for occasions with requirements such as flow resistance, liquid hammer, opening and closing noise and energy consumption. It can replace the pressure regulating valve, electronic expansion valve and solenoid valve at the same time, and play the role of pressure regulation and refrigerant on-off. In the R32 system, it can be used as a safety valve to immediately cut off the system circuit once a refrigerant leak is detected.

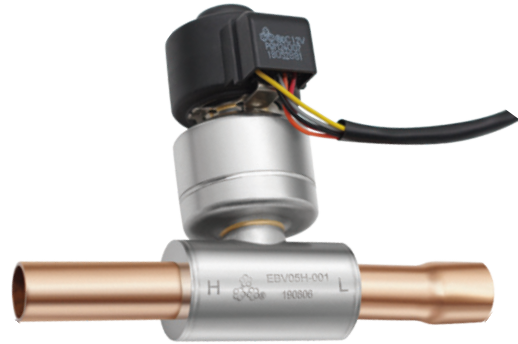

FEATURES

SOLENOID VALVE FUNCTION:

- Bidirectional on-off control
- Slowly open and close, avoid water hammer and fluid impact noise
- Energy-saving, only energy consumption during the operation process
- Full-port ball valve core, large flow, low pressure loss

FLOW REGULATE FUNCTION:

- Full open flow is large, pressure loss is small
- High precision in small flow regulation
- Low internal leakage, fully closed can be used as a shut-off valve

GENERAL SPECIFICATIONS

- Applicable for all common HCFC, HFC refrigerants such as: R134a, R404A, R407C, R410A, R32, R454B etc.
- Medium temperature TS min. /max.: -40°C ~+120°C
- Ambient temperature min. /max.: -30°C ~+70°C
- Relative humidity: Below 100% RH
- Full stroke: EBV05/EBV07 2800 steps
EBV05/EBV09 (External Coil) 4000steps
EBV09 (Built-in Motor) 3500steps
- Installation position:
 - Coil installed in the upwards position, valve body central axis within $\pm 15^\circ$ versus vertical axis

EBV Series

Electric Ball Valve



ELECTRICAL PARAMETERS

- Actuating mode: EBV03/EBV05/EBV07/EBV09 (External Coil) 2-2 Phase excitation, unipolar and bipolar actuation are optional
EBV09 (Built-in Motor) bipolar actuation
- Excitation rate: EBV03/EBV09 (Built-in Motor) 200pps
EBV05 200pps
EBV07/EBV09 (External Coil) 100pps
- End excitation mode holding 0.1~1.0 sec
- Insulation class of coil: E
- Protection class: IP67

TECHNICAL PARAMETER

Model	Connections		MOP	OPD		Cv	Medium temperature	Ambient temperature	Application
	Øin	Øout		H-L	L-H				
	[inch]	[inch]	[MPa]	[MPa]	[MPa]	[m ³ /h]	[°C]	[°C]	
EBV03H001	3/8	3/8	4.3	3	3	4	-40/+120	-30/+55	
EBV03H002	1/2	1/2	4.3	3	3	6	-40/+120	-30/+55	
EBV05H050	5/8	5/8	4.3	3	3	10	-40/+120	-30/+55	Applicable to oil-free system
EBV05H051	3/4	3/4	4.3	3	3	10	-40/+120	-30/+55	
EBV07H-002	7/8	7/8	4.3	1.5	0.5	20	-40/+120	-30/+55	
EBV07H-003	1-1/8	1-1/8	4.3	1.5	0.5	20	-40/+120	-30/+55	
EBV07H-006	7/8	7/8	4.3	3	1.5	20	-40/+120	-30/+55	
EBV09H008	1-1/8	1-1/8	4.3	1.0	/	34	-40/+120	-30/+55	Applicable to oil-free system
EBV09H009	2-1/8	2-1/8	4.3	1.0	/	34	-40/+120	-30/+55	
EBV09H010	1-5/8	1-5/8	4.3	1.0	/	34	-40/+120	-30/+55	
EBV09H-001	1-1/8	1-1/8	4.3	3	1	34	-40/+120	-30/+55	

DIMENSIONS

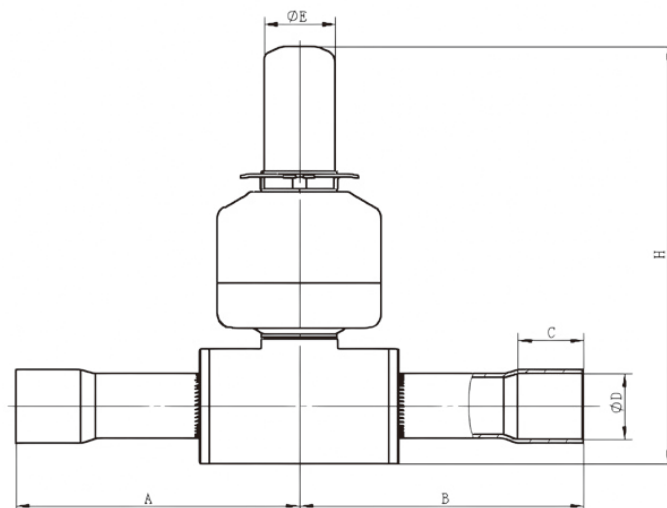

EBV Series

Electric Ball Valve



Model	Connections		Dimension				
	øD		A	B	C	øE	H
	[inch]	[mm]	[mm]	[mm]	[mm]	[mm]	[mm]
EBV03H001	3/8	9.52	55	55	10	17.3	79
EBV03H002	1/2	12.7	51.5	51.5	12	17.3	79
EBV05H050	5/8	15.88	69.4	69.4	13	17.3	102
EBV05H051	3/4	19.05	80.6	80.6	17	17.3	102
EBV07H-002	7/8	22.2	93	90	17.5	17.3	109
EBV07H-003	1-1/8	28.6	102	100	20	17.3	109
EBV07H-006	7/8	7/8	93	90	17.5	17.3	110
EBV09H008	1-1/8	28.6	113	109	32.8	17.3	109
EBV09H009	2-1/8	54	91	88	30	17.3	119
EBV09H010	1-5/8	41.5	91	88	30	17.3	119

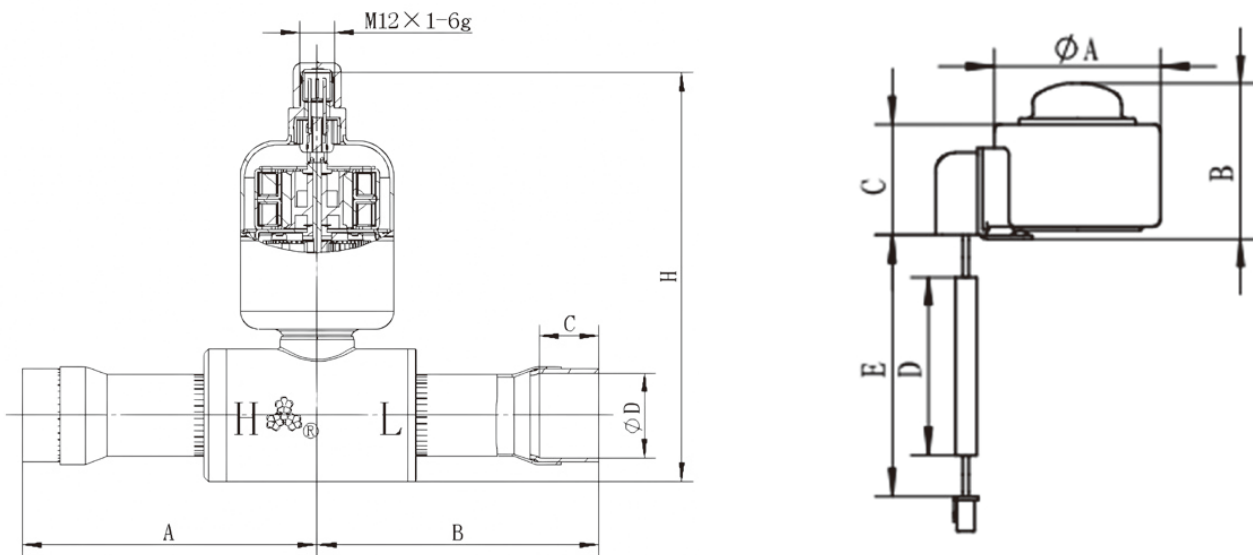

Model	Connections		Dimension			
	øD		A	B	C	H
	[inch]	[mm]	[mm]	[mm]	[mm]	[mm]
EBV09H-001	1-1/8	28.6	100	96	20	139

Coil model	Actuating model	Dimension [mm]					Terminal model	Applicable valve series
		ØA	B	C	Cable length	D		
PQ-M10012-001059	Unipolar	38.5	35.8	25.6	700	600	XHP-5	EBV03/EBV05/ EBV07/EBV09
PQ-M10012-001016	Unipolar	38.5	35.8	25.6	1500	1400	XHP-5	
PQ-M10012-001002	Unipolar	38.5	35.8	25.6	2000	1800	XHP-5	
PQ-M35012-001003	Bipolar	38.5	35.5	25.6	6000	5700	-	

EBV Series

Three Way Electric Ball Valve

The EBV refrigerant three-way electric ball valve can be used in commercial air conditioning systems for heat recovery, constant temperature dehumidification, and other occasions, achieving refrigerant on-off and flow regulation for the A and B outlet paths.

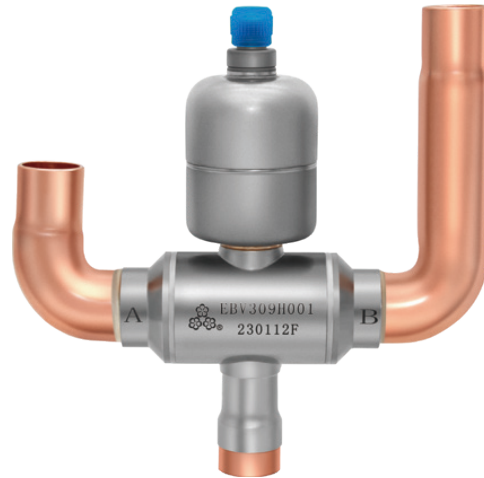

FEATURES

- FULL STAINLESS STEEL VALVE BODY DESIGN, HIGH STRENGTH, CORROSION RESISTANT
- PRECISE FLOW DISTRIBUTION ADJUSTMENT, MINIMAL FLOW FLUCTUATION
- COMPACT DESIGN, REQUIRING MINIMAL INSTALLATION SPACE
- LIGHTWEIGHT DESIGN, GOOD VIBRATION RESISTANCE
- HIGH OPERATING LIFE

GENERAL SPECIFICATIONS

- Applicable for all common HCFC, HFC refrigerants such as: R410A, R32, R134a, R404A, R407C, etc.
- Medium temperature TS min. /max: -40°C ~+120°C
- Ambient temperature: -30°C ~+60°C
- Relative humidity: below 100% RH

ELECTRICAL PARAMETERS

- Rated voltage: 12V DC
- Motor resistance: 52Ω/46Ω
- Full stroke: 3800 steps/4400 steps
- Actuating mode: 2-2 Phase excitation, unipolar and bipolar actuation are optional
- Excitation rate: 100pps
- End excitation mode holding 0.1-1.0s
- Protection class: IP67

EBV Series

Three Way Electric Ball Valve



DIMENSIONS

Model	Connections		MOP	OPD	Cv
	Øin	Øout			
	[inch]	[inch]	[MPa]	[MPa]	
EBV305H001	5/8	5/8	4.3	3	4
EBV305H002	1/2	1/2	4.3	3.1	4
EBV309H001	7/8	7/8	4.3	2.8	10

DIMENSIONS

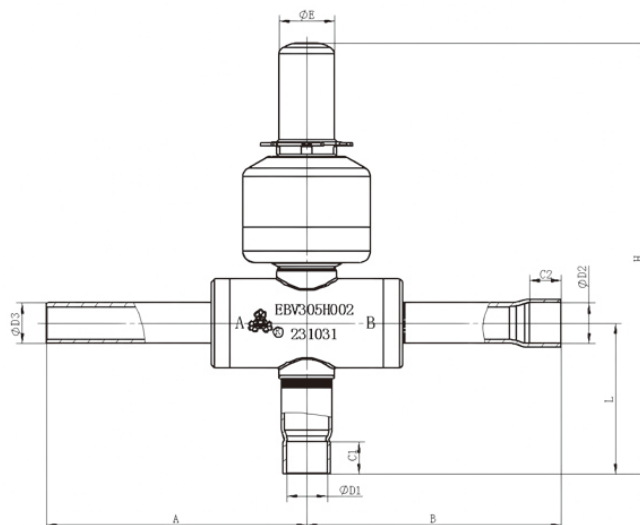

Model	Connections					Dimensions				
	ØD1	ØD2	ØD3	C1	C2	A	B	L	H	ØE
	[inch]	[inch]	[inch]	[mm]	[mm]	[mm]	[mm]	[mm]	[mm]	[mm]
EBV305H001	5/8	5/8	5/8	12.7	16	72	74	47.3	135.2	17.3
EBV305H002	1/2	1/2	1/2	10	10	81.8	79.9	47.3	135.2	17.3

EBV Series

Three Way Electric Ball Valve

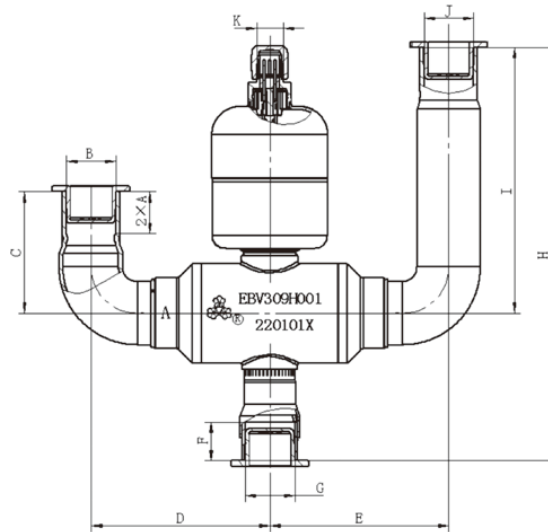

Model	Model [mm]										
	A	B	C	D	E	F	G	H	I	J	K
EBV309H001	19.5	22.35	55	80	80	17.5	22.4	186.5	120	22.35	M12×1

TRAFFIC CHARACTERISTICS

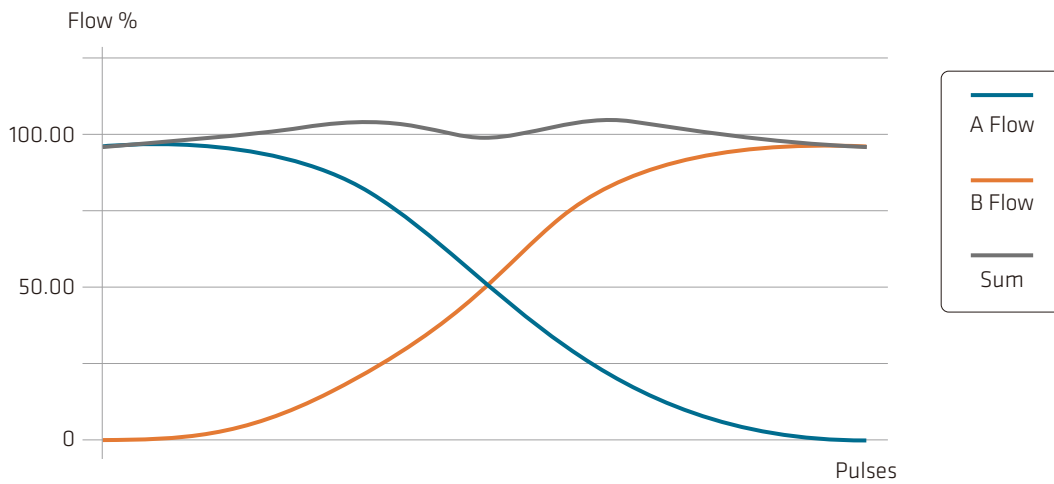

BPHE Series

Brazed Plate Heat Hxchanger

SANHUA plate heat exchanger can be applied to high temperature heat pump in high temperature hot water system condenser. The plate adopts an optimized shallow fishbone design, which has strong reliability, high heat transfer efficiency and reduced pressure. SANHUA stainless steel plate heat exchanger is aimed at the global market and has obtained the European Union PED Class III certification. It is suitable for Class 1 and Class 2 fluids, including water, ethylene glycol solution, various HCFC, HFC, HC and HFO refrigerants, such as R515B, R245fa, R1233zd (E), R1343, R123, R32, etc. The maximum working pressure reaches 4.9 MPa and the maximum working temperature reaches 200°C .



FEATURES

- Compact structure
- Good reliability
- High heat exchange efficiency
- Low pressure drop

GENERAL SPECIFICATIONS

- Applicable refrigerants: R515B, R245fa, R1233zd (E), R1343, R123, R32, etc
- Operating temperature: -196 °C~ + 200°C

PRODUCTS SERIES

	S6B	S11A	S12B	S14B	S20	S20B/S20C	S27C	S30A	S40A	S60/S60B/S60C	S65A	S95B/S95C
650mm						▲				▲		
550mm												
450mm												
350mm												
250mm												
150mm												
50mm												
	54x119	76x154	77x192	77x213	75x317	76x318	116x314	97x327	118x332	119x526	119x534	196x621[mm]
	CE	CE UK CA	CE UK CA	CE UK CA	CE UK CA	CE UK CA	CE UK CA	CE UK CA	CE UK CA	CE UK CA	CE UK CA	CE UK CA
			RU US	RU US	RU US	RU US			RU US	RU US		

Note: ▲ Preferred model for the same size.

BPHE Series

Brazed Plate Heat Hxchanger



TECHNICAL PARAMETER

BPHE series	Max. no. of plate (N)	Max. flow	Hight	Max. working pressure	Working temperature	Plate material	Connection material	Connection (Refrigerant side) ¹⁾	Connection (Water side) ¹⁾
		[m ³ /h]	[mm]	[MPa]	[°C]				
S6B	60	1.7	6+1.3N	4.9 (F1F2)/ 4.9 (F3F4)	-196/200	316L/ SUS 304	316L/ SUS 304	Solder: 1/4", 3/8"	Thread: 1/4", 3/8"
S11A	60	1.7	8+N	4.9 (F1F2)/ 4.9 (F3F4)	-196/200	316L/ SUS 304	316L/ SUS 304	Solder: 3/8", 1/2", 5/8", 3/4"	Thread: 3/8", 1/2", 5/8", 3/4" Solder: 3/8", 1/2", 5/8", 3/4"
S12B	60	1.7	9+N	4.9 (F1F2)/ 4.9 (F3F4)	-196/200	316L/ SUS 304	316L/ SUS 304	Solder: 3/8", 1/2", 5/8", 3/4"	Thread: 3/8", 1/2", 5/8", 3/4" Solder: 3/8", 1/2", 5/8", 3/4"
S14B	60	4	10+2.15N	4.9 (F1F2)/ 4.9 (F3F4)	-196/200	316L/ SUS 304	316L/ SUS 304	Solder: 1/4", 3/8", 1/2", 5/8", 3/4", 7/8"	Thread: 1/4", 3/8", 1/2", 5/8", 3/4"
S20	60	4	10+2.25N	3.0 (F1F2)/ 4.9 (F3F4)	-196/200	316L/ SUS 304	316L/ SUS 304	Solder: 1/4", 3/8", 1/2", 5/8", 3/4", 7/8"	Thread: 1/4", 3/8", 1/2", 5/8", 3/4" Solder: 1/4", 3/8", 1/2", 5/8", 3/4"
S20B	60	4	9+1.5N	4.9 (F1F2)/ 4.9 (F3F4)	-196/200	316L/ SUS 304	316L/ SUS 304	Solder: 1/4", 3/8", 1/2", 5/8", 3/4", 7/8"	Thread: 1/4", 3/8", 1/2", 5/8", 3/4" Solder: 1/4", 3/8", 1/2", 5/8", 3/4"
S20C	60	4	10+2.25N	4.2 (F1F2)/ 4.2 (F3F4)	-196/200	316L/ SUS 304	316L/ SUS 304	Solder: 1/4", 3/8", 1/2", 5/8", 3/4", 7/8"	Thread: 1/4", 3/8", 1/2", 5/8", 3/4" Solder: 1/4", 3/8", 1/2", 5/8", 3/4"
S27C	120	5.5	12+2.25N	4.9 (F1F2)/ 4.9 (F3F4)	-196/200	316L/ SUS 304	316L/ SUS 304	Solder: 1/4", 3/8", 1/2", 5/8", 3/4", 7/8"	Thread: 1/4", 3/8", 1/2", 5/8", 3/4" Solder: 1/4", 3/8", 1/2", 5/8", 3/4"
S30A	120	6	11.5+1.54N	2.5 (F1F2)/ 4.9 (F3F4)	-196/200	316L/ SUS 304	316L/ SUS 304	Solder: 1/4", 3/8", 1/2", 5/8", 3/4", 7/8"	Solder: 1/4", 3/8", 1/2", 5/8", 3/4"
S40A	120	8.8	10.5+1.53N	2.5 (F1F2)/ 4.9 (F3F4)	-196/200	316L/ SUS 304	316L/ SUS 304	Solder: 1/4", 3/8", 1/2", 5/8", 3/4", 7/8"	Thread: 1/4", 3/8", 1/2", 5/8", 3/4"
S60	120	17	9+2.3N	3.0 (F1F2)/ 4.9 (F3F4)	-196/200	316L/ SUS 304	316L/ SUS 304	Solder: Up to 1"3/8	Thread: Up to 1"1/4
S60B	120	17	13+1.86N	3.0 (F1F2)/ 4.9 (F3F4)	-196/200	316L/ SUS 304	316L/ SUS 304	Solder: Up to 1"3/8	Thread: Up to 1"1/4
S60C	120	17	13+2.2N	2.5 (F1F2)/ 4.5 (F3F4)	-196/200	316L/ SUS 304	316L/ SUS 304	Solder: Up to 1"3/8	Thread: Up to 1"1/4
S65A	120	6	12+1.4N	2.5 (F1F2)/ 3.2 (F3F4)	-196/200	316L/ SUS 304	316L/ SUS 304	Solder: 1/4", 3/8", 1/2", 5/8", 3/4", 7/8", 1", 1"1/4, 1"3/8	Thread: 1/4", 3/8", 1/2", 5/8", 3/4", 7/8", 1", 1"1/4
S95B	250	35	14+2.28N	4.9 (F1F2)/ 4.9 (F3F4)	-196/200	316L/ SUS 304	316L/ SUS 304	Solder: Up to 2"1/8	Thread: Up to 2"
S95C	250	35	14+2.28N	2.5 (F1F2)/ 4.9 (F3F4)	-196/200	316L/ SUS 304	316L/ SUS 304	Solder: Up to 2"1/8	Thread: Up to 2"

Note: 1)For S6B, it is the evaporation side and the supercooled side.

YCQB Series

Pressure Transducer

Pressure transducer are widely used in high temperature heat pump systems. Using a 5 V excitation input these sensors provide a 0.5-3.5 V or 0.5-4.5 V ratiometric signal output proportional to the pressure of the medium. This device requires no end user amplification. Pressure transducers permit to control and guarantee the system working under safe and stability condition.



FEATURES

- Overall features: applied high performance digital circuit which has good linear, small temperature excursion and high level of accuracy over wide operating range
- Small size and simple installation; models available with lead wire direct connector or with packard and molex socket connections;
- Stability: applied superior pressure core, good stability under strict process control;
- Diversification: different pressure ranges and different level of accuracy.

GENERAL SPECIFICATION

- Applicable for all common HCFC, HFC and HFO refrigerants such as: R22, R134a, R404A, R407C, R410A, R507, R1233zd (E), R1234yf ect.
- Medium temperature: -30 °C ~+40 °C ($\pm 0.8\%$ FS accuracy)
-30 °C ~+120 °C ($\pm 2\%$ FS accuracy)
-30 °C ~+150 °C ($\pm 2.5\%$ FS accuracy)
- Ambient temperature: -30 °C ~+80 °C
- Installation position: preferably with vertical axis and sensor upwards
- Certifications: UL, VDE, CE

ELECTRICAL SPECIFICATION

- Supply Voltage: 5V \pm 0.25V DC
- Current Consumption: Max. 10 mA
- Response Time: 10 ms
- Electrical strength: Max. 0.75 mA, AC 1.8KV (1s)
- Insulation Resistance: Min. 100 M Ω
- Load Resistance: Min. 10 k Ω
- Protection Class: IP67 (Lead wires type), IP66

YCQB Series

Pressure Transducer



WORKING RESTRICTIONS

Model	Ambient temperature	Relative humidity	Medium temperature min / max	Comprehensive accuracy and applicable medium temperature	Withstanding pressure [MPa]
YCQB02H50	-30°C~ 80°C	0 ~ 95%	-30°C / +150°C	-30°C ~ +40°C (±0.8% FS Accuracy)	5.25
YCQB04H50				-30°C ~ +120°C (±2% FS Accuracy) -30°C ~ +150°C (±2.5% FS Accuracy)	7.50

TECHNICAL PARAMETER

Model	Connection			Electrical connection	Pressure range (0~pr) [MPa]	Output (VA0~VApr) [V]
	Øin [inch]	Connection [inch]	Thread size			
YCQB02H50	Solder	1/4"	-	Packard	0~1.38	0.5~4.5DC
YCQB04H50	Solder	1/4"	-	Packard	0~3.45	0.5~4.5DC

DIMENSIONS

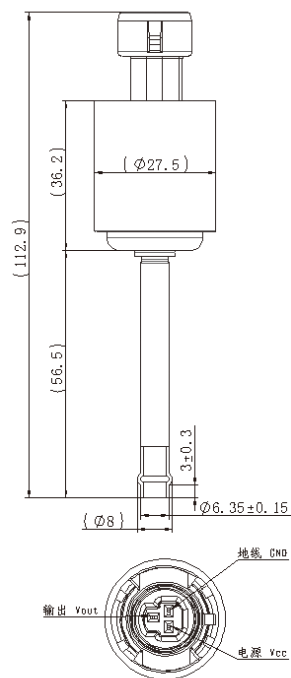

YCQB02H50

YCQB04H50

DTGB Series

Liquid Line Filter Driers

DTGB series liquid line filter driers are used in Uni-flow refrigeration system line to absorb moisture and acidic harmful substances in the refrigeration system and filter impurities in the system.



FEATURES

- Combination of drying and filtering
- High efficient in moisture absorption, filtering impurity, acid, paint remains and mud removal
- Durable and solid filter cores
- Filtering fineness: 20µm
- Corrosion resistant painting survives salt spray test of 500 hours
- Connection type: flare or solder

GENERAL SPECIFICATIONS

- Applicable for all common HCFC, HFC, HC refrigerants, such as R515B, R245fa, R134a, R123, R32 ect.
- Medium temperature TS min. /max.: -30°C / +120°C
- Ambient temperature min. /max.: -30°C / +70°C
- Max. operating pressure PS max.: 4.8MPa (48bar)
- Installation position: Flow direction corresponds to the arrow, preferably installed in liquid line
- Certifications: UL, CUL and PED declaration

DTGB Series

Liquid Line Filter Driers



DTG-B FLARE CONNECTION

Solid core, 100% 3A desiccant

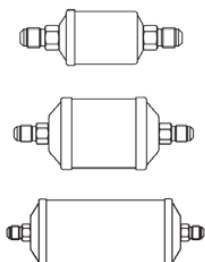

Filter	Model	Connection	Nominal Volume	
		[inch]	[inch ³]	[cm ³]
DTGB033	DTG-B03 034-901	3/8	3	49
DTGB034	DTG-B03 044-901	1/2	3	49
DTGB052	DTG-B05 024-901	1/4	5	82
DTGB053	DTG-B05 034-901	3/8	5	82
DTGB082	DTG-B08 024-901	1/4	8	131
DTGB083	DTG-B08 034-901	3/8	8	131
DTGB084	DTG-B08 044-901	1/2	8	131
DTGB162	DTG-B16 024-901	1/4	16	262
DTGB163	DTG-B16 034-901	3/8	16	262
DTGB164	DTG-B16 044-901	1/2	16	262
DTGB165	DTG-B16 054-901	5/8	16	262
DTGB166	DTG-B16 064-901	3/4	16	262
DTGB303	DTG-B30 034-901	3/8	30	492
DTGB304	DTG-B30 044-901	1/2	30	492
DTGB305	DTG-B30 054-901	5/8	30	492
DTGB306	DTG-B30 064-901	3/4	30	492
DTGB053	DTG-B30 074-901	7/8	30	492
DTGB414	DTG-B41 044-901	1/2	41	672
DTGB415	DTG-B41 054-901	5/8	41	672

DTG-B SOLDER CONNECTION

Solid core, 100% 3A desiccant

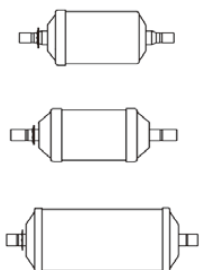

Filter	Model	Connection	Model	Connection	Nominal Volume	
		[inch]		[mm]	[inch ³]	[cm ³]
DTGB0325s	DTG-B03 250-901	5/16	DTG-B03 250-901	8	3	49
DTGB033s	DTG-B03 030-901	3/8	DTG-B03 101-901	10	3	49
DTGB034s	DTG-B03 040-901	1/2	DTG-B03 121-901	12	3	49
DTGB052s	DTG-B05 020-901	1/4	DTG-B05 061-901	6	5	82
DTGB0525s	DTG-B05 250-901	5/16	DTG-B05 250-901	8	5	82
DTGB053s	DTG-B05 030-901	3/8	DTG-B05 101-901	10	5	82
DTGB054s	DTG-B05 040-901	1/2	DTG-B05 121-901	12	5	82

DTGB Series

Liquid Line Filter Driers

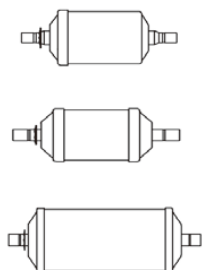

Filter	Model	Connection	Model	Connection	Nominal Volume	
		[inch]		[mm]	[inch ³]	[cm ³]
DTGB055s	DTG-B05 050-901	5/8	DTG-B05 050-901	16	5	82
DTGB082s	DTG-B08 020-901	1/4	DTG-B08 061-901	6	8	131
DTGB0825s	DTG-B08 250-901	5/16	DTG-B08 250-901	8	8	131
DTGB083s	DTG-B08 030-901	3/8	DTG-B08 101-901	10	8	131
DTGB084s	DTG-B08 040-901	1/2	DTG-B08 121-901	12	8	131
DTGB085s	DTG-B08 050-901	5/8	DTG-B08 050-901	16	8	131
DTGB162s	DTG-B16 020-901	1/4	DTG-B16 061-901	6	16	262
DTGB1625s	DTG-B16 250-901	5/16	DTG-B16 250-901	8	16	262
DTGB163s	DTG-B16 030-901	3/8	DTG-B16 101-901	10	16	262
DTGB164s	DTG-B16 040-901	1/2	DTG-B16 121-901	12	16	262
DTGB165s	DTG-B16 050-901	5/8	DTG-B16 050-901	16	16	262
DTGB166s	DTG-B16 060-901	3/4	DTG-B16 060-901-	19	16	262
DTGB167s	DTG-B16 070-901	7/8	DTG-B16 070-901	22	16	262
DTGB303s	DTG-B30 030-901	3/8	DTG-B30 101-901	10	30	492
DTGB304s	DTG-B30 040-901	1/2	DTG-B30 121-901	12	30	492
DTGB305s	DTG-B30 050-901	5/8	DTG-B30 050-901	16	30	492
DTGB306s	DTG-B30 060-901	3/4	-	-	30	492
DTGB307s	DTG-B30 070-901	7/8	DTG-B30 070-901	22	30	492
DTGB309s	DTG-B30 090-901	1 1/8	DTG-B30 281-901	28	30	492
DTGB414s	DTG-B41 040-901	1/2	DTG-B41 121-901	12	41	672
DTGB415s	DTG-B41 050-901	5/8	DTG-B41 050-901	16	41	672
DTGB417s	DTG-B41 070-901	7/8	DTG-B41 070-901	22	41	672
DTGB419s	DTG-B41 090-901	1 1/8	DTG-B41 281-901	28	41	672
DTGB757s	DTG-B75 070-901	7/8	DTG-B75 070-901	22	75	1229
DTGB759s	DTG-B75 090-901	-	DTG-B75 281-901	28	75	1229

PSQ Series Ejector

PSQ series Ejector, used in full-liquid evaporators to eject oil back, increase fluid pressure, and recover low-pressure fluids.

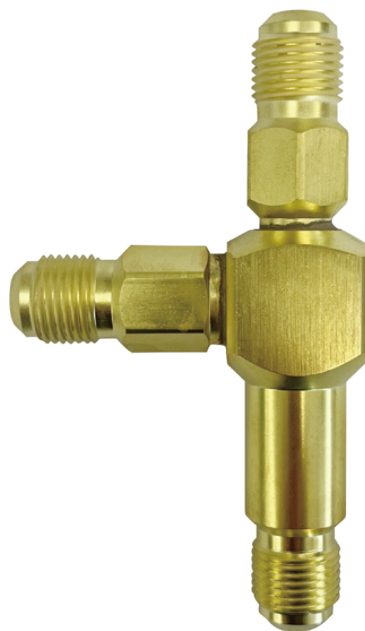

FEATURES

- All-metal design, good strength
- High temperature resistance over 150 °C
- Threaded joint design for easy connection

GENERAL SPECIFICATIONS

- Applicable refrigerants: HFC, HFO and HC refrigerants, such as R515B, R245fa, R1233zd (E) , R134a, R123, R32, etc
- Applicable medium temperature: -40 °C ~ + 150 °C
- Max. working pressure: 4.2MPa
- Connection: All of the threads are 5/8-18 UNF

DIMENSIONS

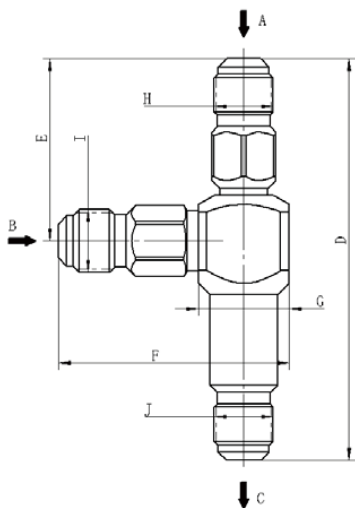

Ejector Series	Dimensions [mm]				Connection		
	D	E	F	G	H	I	J
PSQ-2A01	106.7	48.4	61.3	24*24	5/8-18 UNF	5/8-18 UNF	5/8-18 UNF

PSV15 Series

Pressure Switch

PSV series pressure switch can be used in refrigeration, air conditioning and high temperature heat pump system to protect the systems from extremely low suction pressure or extremely high discharge pressure. The pressure switches also can be used to start or stop the refrigeration compressors and air-cooled condenser fans, to regulate other components in the systems which require pressure control function.



FEATURES

- High level of accuracy and high stability
- Long lifetime with both excellent electric and mechanical reliability
- SPDT switch to ensure good contact and disconnect conversion with fast reactions
- Various pressure ranges are available
- Supply with installation plate
- Bellows elements are made of tin bronze and pressure connections are made of brass

GENERAL SPECIFICATIONS

- Applicable refrigerants: R515B, R245fa, R1233zd (E) and other HCFC, HFC, HC, HFO refrigerants
- Medium temperature: $-40^{\circ}\text{C} / +150^{\circ}\text{C}$
- Ambient temperature: $-30^{\circ}\text{C} / +65^{\circ}\text{C}$
- Max. working pressure: HP: 3.5/4.5Mpa; LP: 1.65Mpa
- Waterproofing grade: IP30/IP44 (to be customized)
- Certifications: CE, PEV IV and UL listed
- Contact load:

Rated Voltage (V)	AC1	AC3	AC15	DC
	400	400	400	24
Rated Current (A)	16	16	10	8

PSV15 Series

Pressure Switch



PRODUCT DESIGNATION LEGEND

Position Number	Model Designation Legend	
1	Pressure Switch Series	Description
	PSV	Pressure Switch
2	Pressure Regulating Range	Description
	15	Dual LP: -0.5~7 bar (g) / HP: 6~32 bar (g)
3	Reset Code	Description
	A	Automatic Reset
	M	Manual Reset
	AA	Auto LP/ Auto HP
	AM/MA/MM
4	Pressure Connection Code	Description
	L	Flare
	H	Solder
	M	Capillary
5	Product Type	Description
	S	Standard
	C	Customized
6	Sequence Number	Description
	0X (01/02/03/04/05/ ...)	PED IV certified models, high pressure dual bellows
	5X (51/52/53/54/55 ...)	Common models, high pressure single bellow

NAMED INSTANCE (refer to the rules above)

1	2	3	4	-	5	6	
PSV	15	AA	L	-	S	01	Pressure Switch
PSV	15	AA	L	-	S	01	Dual pressure range LP: -0.5~7 bar (g) /HP: 6~32 bar (g)
PSV	15	AA	L	-	S	01	Auto reset HP, auto reset LP
PSV	15	AA	L	-	S	01	Flare connection
PSV	15	AA	L	-	S	01	Standard
PSV	15	AA	L	-	S	01	PED IV certified models, high pressure dual bellows

PSV15 Series

Pressure Switch



SELECTION AND ORDERING

PSV15, Flare connection

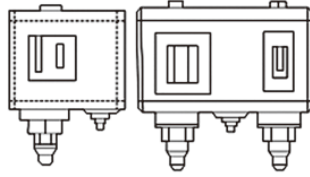

Pressure	Type	LP		HP		Reset		PED 2014 68/EU EN 12263 certification	Connection
		Pressure Range [bar]	Pressure Difference ΔP [bar]	Pressure Range [bar]	Pressure Difference ΔP [bar]	LP	HP		Flare connection 7/16-20UNF (1/4in. ϕ 6mm)
									Model
Dual	PSV15	-0.5 ~ 7	0.7 ~ 5	6 ~ 32	4 fixed	Auto	Auto	No	PSV15AAL-S51
Dual	PSV15	-0.5 ~ 7	0.7 ~ 5	6 ~ 32	4 fixed	Auto	Manual	No	PSV15AML-S51
Dual	PSV15	-0.5 ~ 7	0.7 ~ 5	6 ~ 32	5 fixed	Auto	Auto	Yes	PSV15AAL-S01
Dual	PSV15	-0.5 ~ 7	0.7 ~ 5	6 ~ 32	5 fixed	Auto	Manual	Yes	PSV15AML-S01

Note: Based on the certified by TÜV, Rheinland acc. to PED 2014 68/EU, EN12263 are designed with double bellows at high pressure and they provide fail-safe function (models without PED 2014 68/EU Certificate can be used as pressure regulation devices, usage as pressure safety devices must be verified as per local legislation in the country of use). Regarding availability of PED 2014 68/EU (Category IV) Certificate please contact your Sanhua sales representative.

The double bellows system prevents loss of charge in the event of the inner bellow rupture. A rupture in the inner bellow will cause the control cut-out pressure to fall about 3 times less the set value and the compressor will stop. A rupture in the outer bellows will cause the control cut-out pressure to fall to about 3 bar under the set value and providing the so-called 'fail-safe' function.

DIMENSIONS

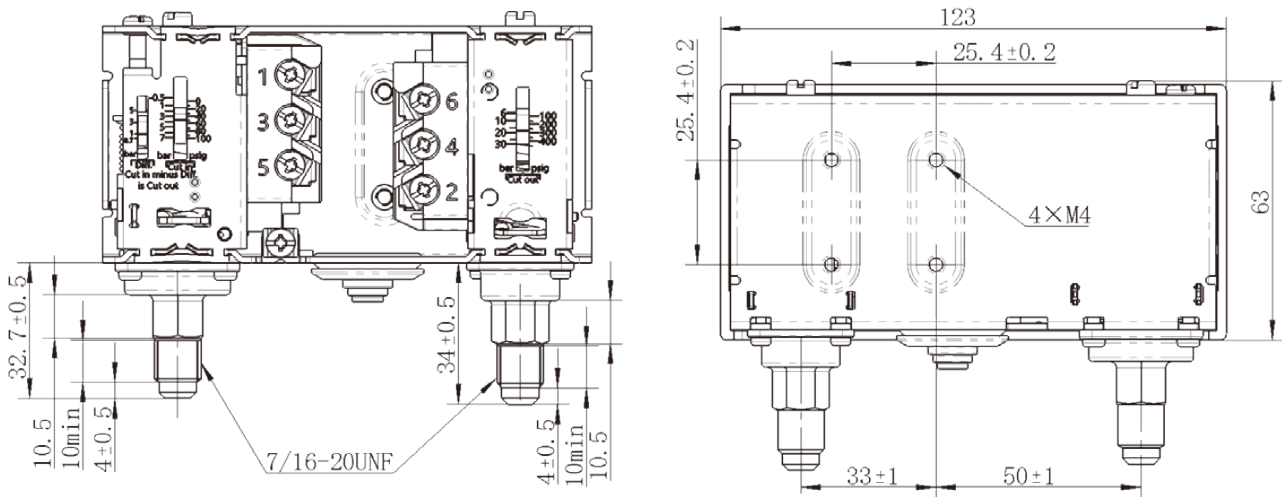

PSV15 × × L

PSV15 Series Pressure Switch



MOUNTING PLATE

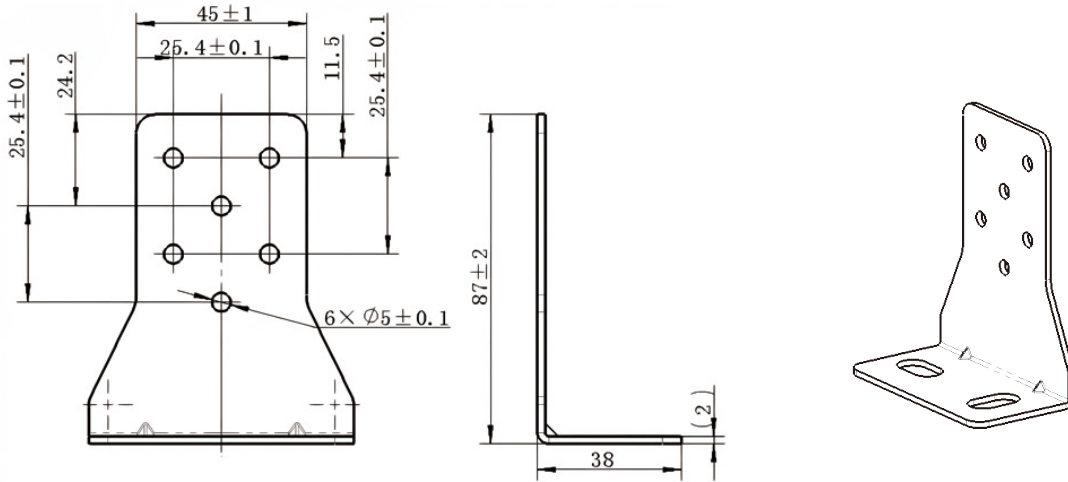

CONTACT SYSTEM

Dual PSV15AA

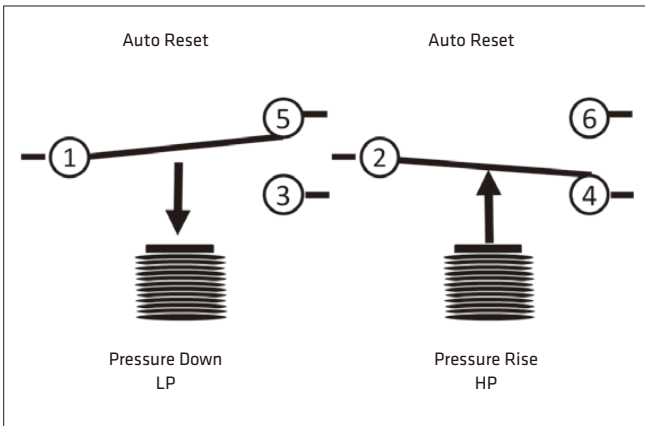

Dual PSV15AM

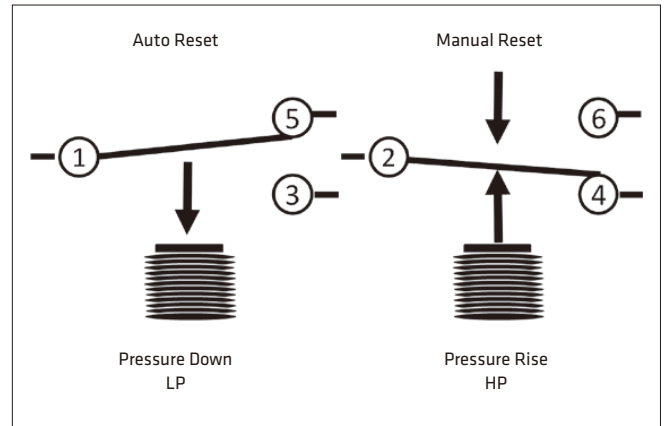

innovating TOGETHER



SANHUA refrigeration
official account



SANHUA official
website



Zhejiang Sanhua Commercial Refrigeration Controls Co.,Ltd
<http://commercial.sanhuagroup.com>

SANHUA is not responsible for possible errors in its manuals, catalogs and other printed materials.

SANHUA reserves the right to make changes to products without prior notice. This also applies to products ordered but not delivered provided that such alterations can be made without changes to form, fit or function of the product.

Published in Jan./2025

