

## YFQ-F SERIES

# Oil Separators

YFQ-F series oil separators are used for commercial AC and refrigeration system, be installed at the outlet of compressor to separate gas and oil, to ensure oil returns to compressor and reduce oil entering system.



### FEATURES

- OIL SEPARATION EFFICIENCY IS OVER 90%
- OPTIMIZED STRUCTURE DESIGN TO REDUCE PRESSURE DROP AND NOISE DURING OPERATION
- CORROSION RESISTANT PAINTING SURVIVES SALT SPRAY TEST OF 500 HOURS

### GENERAL SPECIFICATIONS

- Applicable refrigerants: R22, R502, R134A, R407A, R410A, etc.
- Medium temperature: -30°C~+120°C(-22°F~+248°F)
- Ambient temperature: -30°C~+55°C(-22°F~+131°F)
- PS: 4.15MPa
- Certifications: UL and PED declaration



**TECHNICAL PARAMETERS**

Model	Solder Connection ODF [Inch]	Shell OD [mm]	Length [mm]	Oil pre-charge amount [ml]
YFQ-F00101-001	3/8	101.6	220	400
YFQ-F00101-002	1/2		287	
YFQ-F00101-003	5/8		341	
YFQ-F00101-004	7/8		396	
YFQ-F00101-005	1-1/8		426	

**CAPACITY TABLE**

Model	R22/R407C		R134a		R404A/R507		R410A	
	-40°C	4°C	-40°C	4°C	-40°C	4°C	-40°C	4°C
	kW	kW	kW	kW	kW	kW	kW	kW
YFQ-F00101-001	5.0	6.8	3.1	6.0	5.1	6.8	6.8	9.3
YFQ-F00101-002	5.3	7.0	3.2	6.2	5.3	7.0	8.1	10.6
YFQ-F00101-003	15.8	19.3	11.4	15.8	14.4	19.3	24.0	29.3
YFQ-F00101-004	24.6	28.1	16.7	22.4	22.8	28.8	37.4	42.2
YFQ-F00101-005	31.7	37.0	22.4	29.9	30.0	37.4	52.8	56.2

**DIMENSIONS**

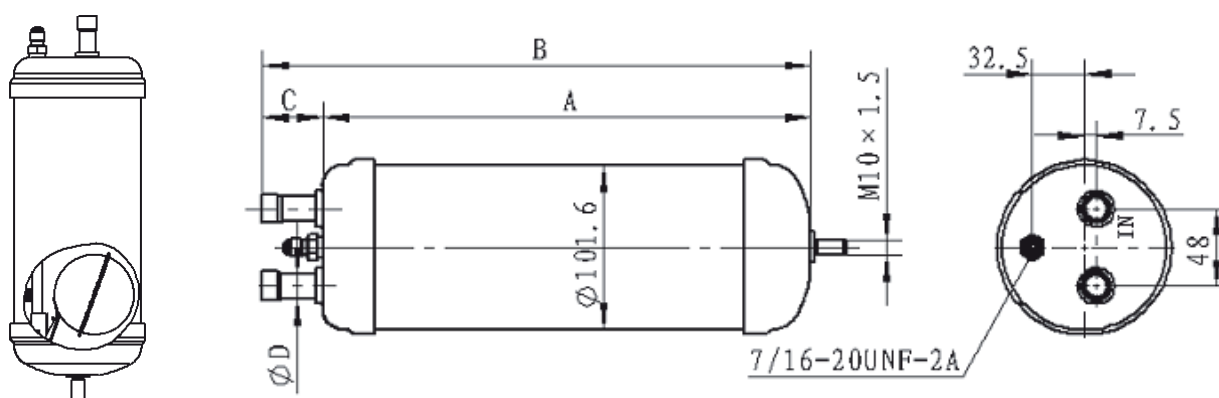

Model	Dimensions			
	A [mm]	B [mm]	C [mm]	D [Inch]
YFQ-F00101-001	187	220	33	3/8
YFQ-F00101-002	254	287	33	1/2
YFQ-F00101-003	303	341	38	5/8
YFQ-F00101-004	351	396	45	7/8
YFQ-F00101-005	376	426	50	1-1/8